

DRI-Line Series: 'RM (Remote Blower) Drying System

Configuration	Remote Blower Drying System
Product Category	All bottles/cans/pouches etc
Application Area	Drying specific or complete areas

Without compromising reliability or performance, ACI's 'RM' System is designed to offer a drying solution that does not compromise performance efficiency. The system is ideal for budget restricted/low-volume applications.

System options:

Option	Blower Specification	Airknife Length	ACI Part Number
1	15kW EP10A Blower (18-19,000 rpm)	2 x 1200mm St St Airknives each fitted with x2 flexible nozzles	RMB-01 15KW
2	15kW EP10A Blower (18-19,000 rpm)	2 x JetPlates, 2 x 320mm St St Airknives	RMB-02 15KW
3	15kW EP10A Blower (18-19,000 rpm)	Can Tunnel (4 slot) with 2 x 500mm St St Airknives	RMB-03 15KW

Illustration (Anodised Aluminium Airknives):

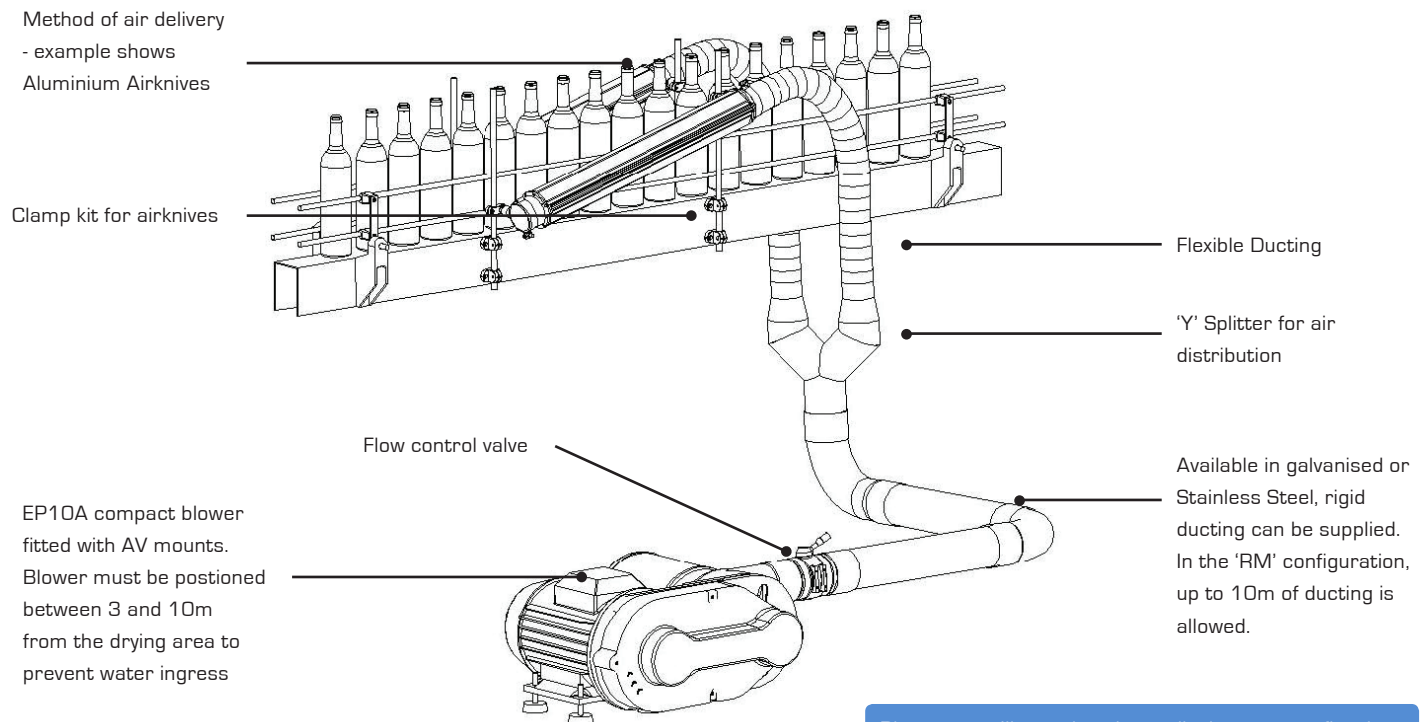

Please note [1] - all drawings measurements are in millimeters (mm)
 Please note [2] - technical specifications are subject to change

Please note: Illustration shown displays system fitted with Aluminium Airknives. All of ACI's air delivery options can be supplied in the 'RM' configuration.

System description:

The RM system is characterised by having no enclosures supplied for either spray contamination or noise. The blower also must be positioned at least 3 metres and a maximum of 10 metres from the drying area - this will ensure no spray contamination of the blower.

Outline drawing (illustrated with JetPlates):

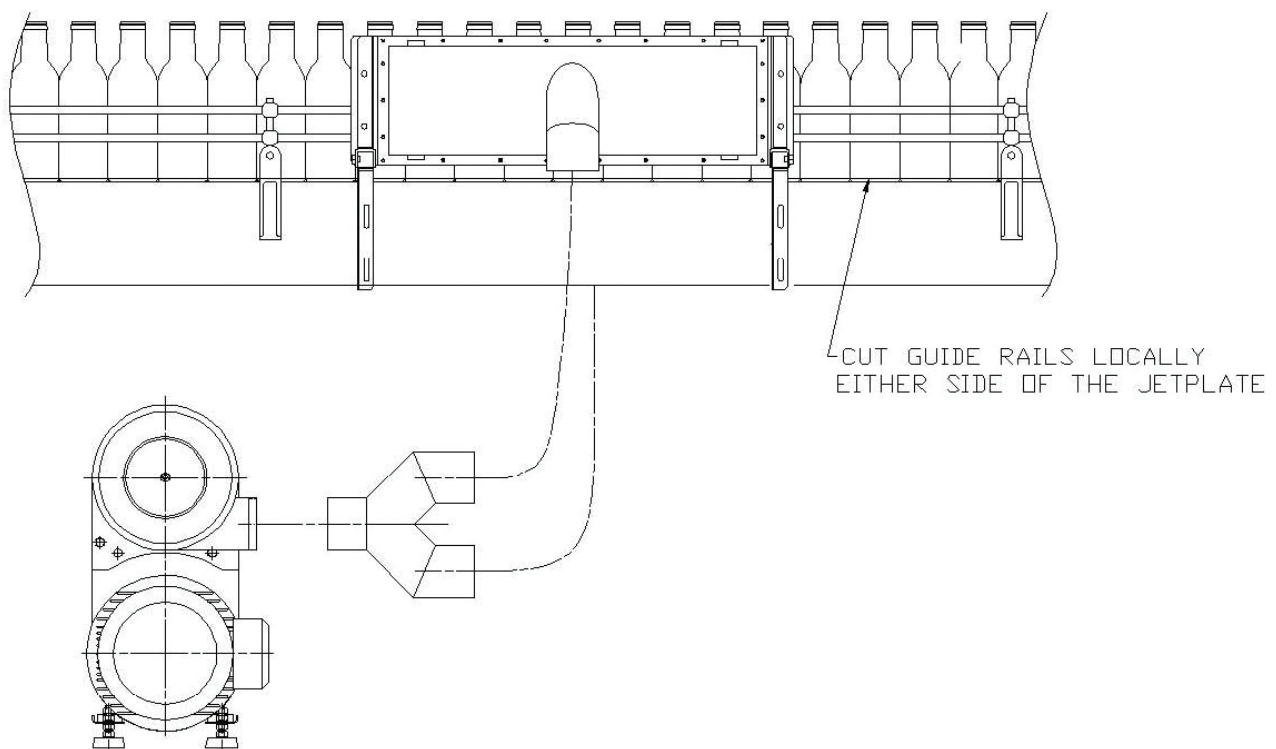

Other options:

These will include the following:

Air delivery devices

ACI can offer a number of alternatives to delivering the air to the product, including Stainless Steel air knives, JetPlates, Can Tunnels, Neck and Cap Dryers.

Ducting

In addition to standard flexible hose, both solid stainless or galvanised steel are available.

Enclosures and pedestals

A number of mounting configurations/blower enclosures are available. Detailed advice can be given to customers on application by ACI's Technical Sales Department

Starters

ACI are able to offer a range of starters for all budgets.