

Compact Blower EP10A: Belt Driven Centifugal Blower

Specifications

Motor Type	Induction Type/TEFC/IP55
Nominal Supply	380/420VY/660-690Y 3Ph 50Hz 440-480D 3Ph 60Hz
Materials	<ul style="list-style-type: none"> • Main housing assembly: aluminium • Impeller: aluminium • Shaft assembly: hardened tool steel • Drive pulley: steel • Motor pulley: aluminium
Mounting	Anti Vibration Feet
Noise Levels	82-91 dB(A) Free Air, @ 1 metre depending on blower speed.
Weight	70.0Kg (7.5kW motor plus fan)
Variations	EP10AH (Hot air version)



Outline Dimensions

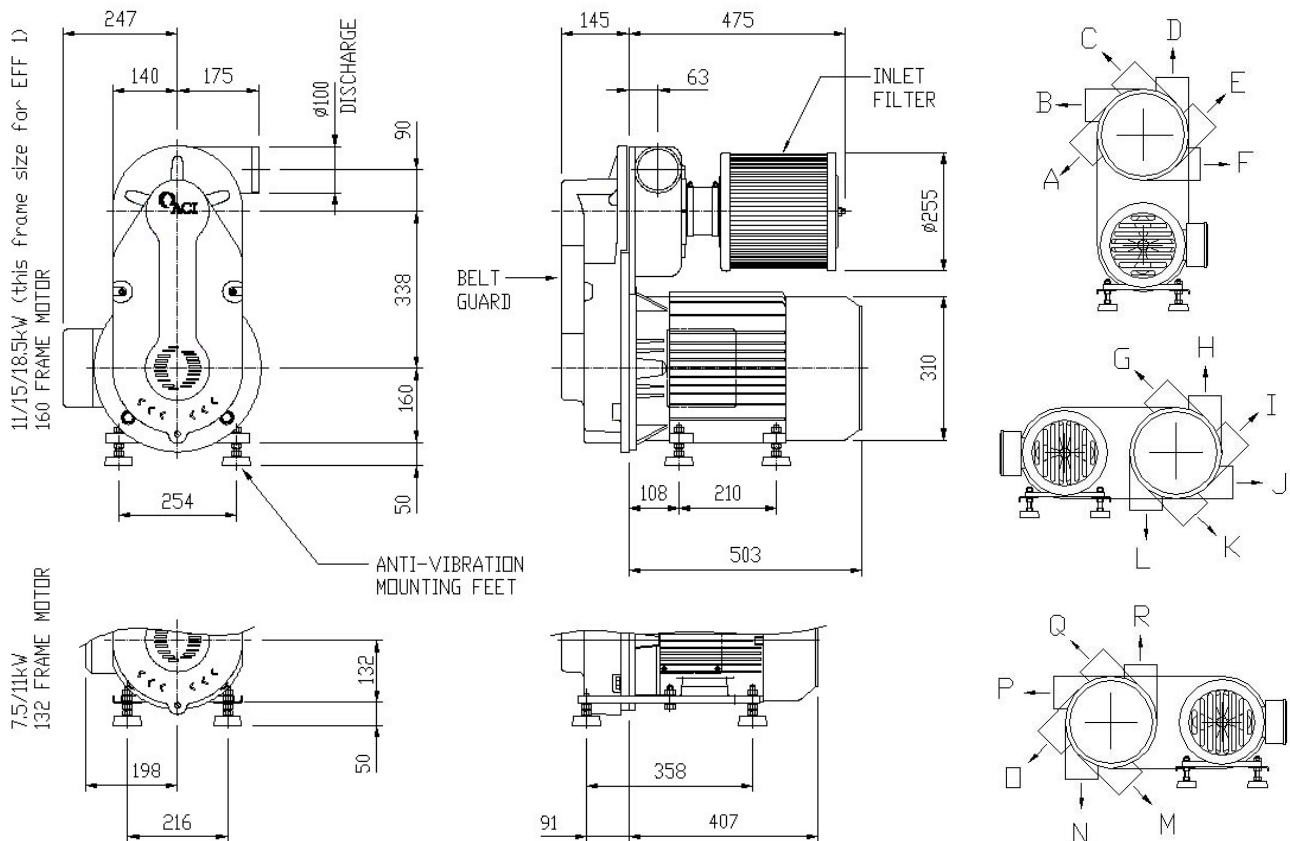

Please note (1) - all drawings measurements are in millimeters (mm)

Please note (2) - above technical specifications are subject to change

Pressure Performance Curves

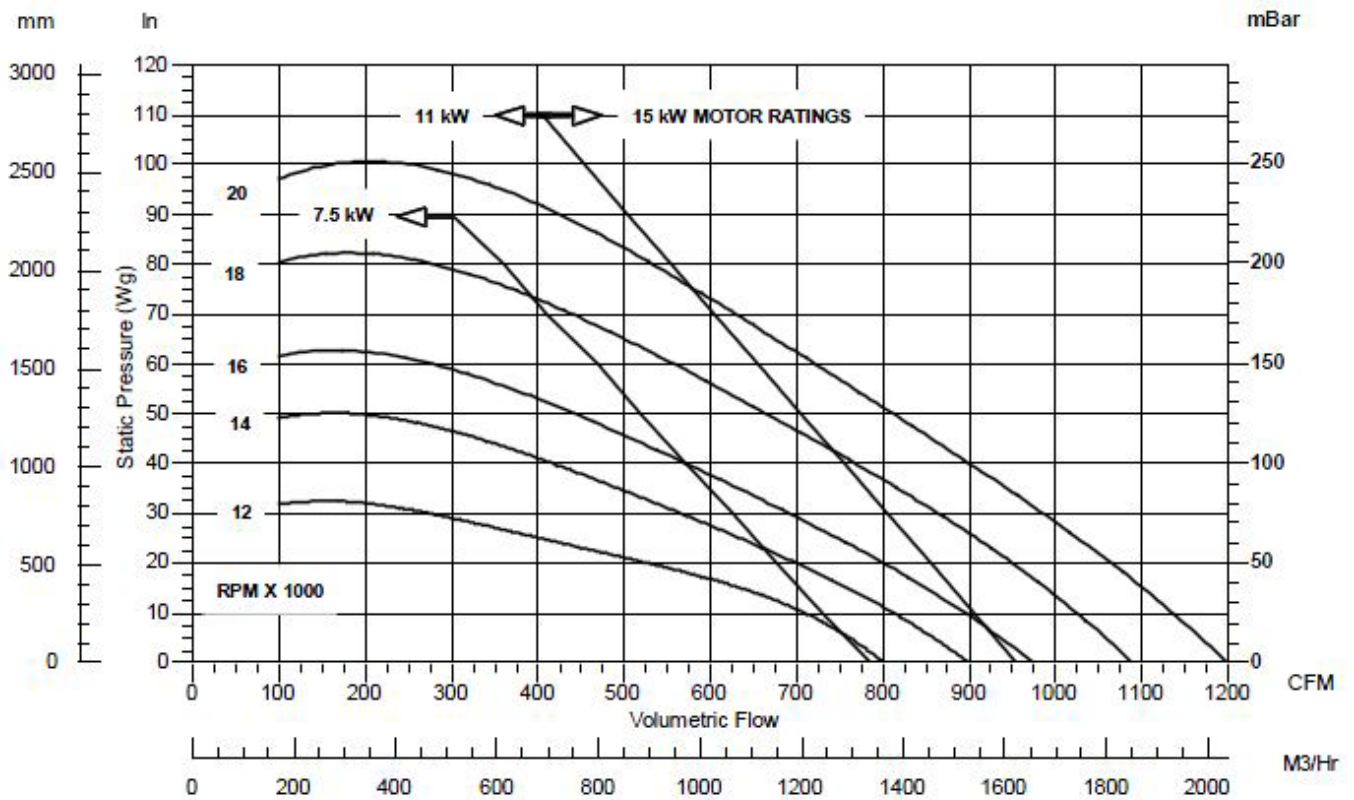

Vacuum Performance Curves

